

# Spin-Orbit Interactions in **Nuclei** and **Hypernuclei**

Wolfram Weise  
Technische Universität München



- Phenomenology
- Aspects of Chiral Dynamics and Spin-Orbit Forces
- Nuclei vs.  $\Lambda$ -Hypernuclei:  
understanding the Spin-Orbit Puzzle

## References:

- N. Kaiser and W.W., Nucl. Phys. A804 (2008) 60  
P. Finelli, N. Kaiser, D.Vretenar and W.W., Phys. Lett. B658 (2007) 90  
N. Kaiser and W.W., Phys. Rev. C71 (2005) 015203  
S. Fritsch, N. Kaiser and W.W., Nucl. Phys. A750 (2005) 259  
N. Kaiser, Phys. Rev. C70 (2004) 034307  
N. Kaiser, S. Fritsch and W.W., Nucl. Phys. A724 (2003) 47



1.

**Nuclear and Hypernuclear  
Spin-Orbit Forces:  
Phenomenology**



# Nuclear Shell Model Phenomenology

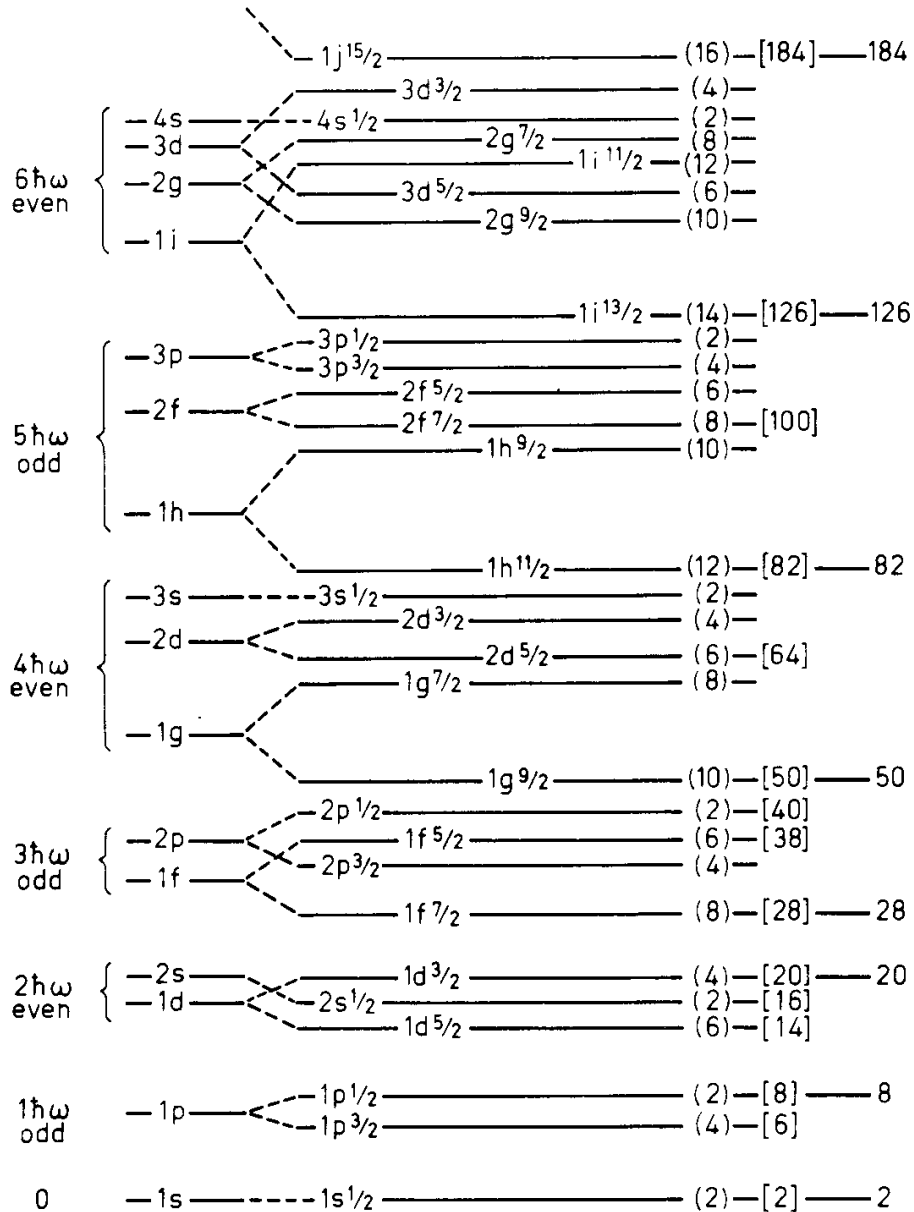

M. Goeppert-Mayer, J.H.D. Jensen (1955)

## Spin-Orbit Interaction

$$\Delta \mathcal{H}_{LS} = \frac{U_{LS}}{r} \frac{df(r)}{dr} \vec{L} \cdot \vec{s}$$

$$\vec{L} = -i \vec{r} \times \vec{\nabla} \quad \vec{s} = \frac{1}{2} \vec{\sigma}$$

$$f(r) = \frac{\rho(r)}{\rho_0} = \left( 1 + \exp \frac{r - R}{a} \right)^{-1}$$

$$U_{LS} \simeq 30 \text{ MeV} \cdot \text{fm}^2$$

- unusually large:**  
 one order of magnitude larger than expectation from Thomas term based on single particle potential and opposite sign



# Skyrme Phenomenology

- **Energy Density** of slightly inhomogeneous nuclear matter
- **Spin-Orbit** part of energy density functional

$$\Delta\mathcal{E}_{\text{LS}}[\rho] = \mathbf{F}_{\text{LS}}(\rho) \vec{\nabla}\rho \cdot \sum_{\alpha \in \mathbf{F}} \Psi_{\alpha}^{\dagger}(\vec{\mathbf{r}}) \mathbf{i}\vec{\sigma} \times \vec{\nabla}\Psi_{\alpha}(\vec{\mathbf{r}})$$

$$\mathbf{F}_{\text{LS}}(\rho_0) \simeq 90 \text{ MeV} \cdot \text{fm}^5$$

- Relation between shell model phenomenology and Skyrme parametrization

$$\mathbf{F}_{\text{LS}}(\rho) = 2\rho \mathbf{U}_{\text{LS}}(\rho)$$



# Phenomenology (part I): Strong **Scalar-Vector** Mean Fields

- **Short-distance** contribution to spin-orbit interaction

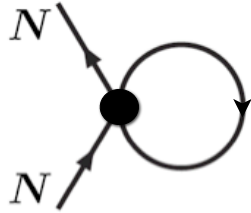

$$\mathbf{F}_{LS}^{sr} = \frac{\mathbf{G}_S + \mathbf{G}_V}{4M_N^*} = \frac{1}{4M_N^*} \left( \frac{g_\sigma^2}{m_\sigma^2} + \frac{g_\omega^2}{m_\omega^2} \right)$$

- **Equivalent** descriptions:

- ▶ “**sigma-plus-omega**” boson exchange models á la Walecka
- ▶ **contact** terms in NN Effective Field Theory
- ▶ **strong scalar-vector** mean fields from QCD Sum Rules

$$\begin{aligned} \Sigma_S &= -\mathbf{G}_S \rho_S & \frac{\Sigma_S}{\Sigma_V} &\simeq \frac{-\sigma_N}{4(m_u + m_d)} \left( \frac{\rho_S}{\rho} \right) \sim -1 & \mathbf{G}_S &\simeq \frac{\sigma_N M_N}{m_\pi^2 f_\pi^2} \simeq 10 \text{ fm}^2 \\ \Sigma_V &= \mathbf{G}_V \rho \end{aligned}$$

(Cohen, Furnstahl; PRL 67 (1991) 961)

- **Result:** empirical  $\mathbf{F}_{LS}(\rho_0) \simeq 90 \text{ MeV} \cdot \text{fm}^5$

“understood” at Hartree level in terms of short-distance NN dynamics



# Phenomenology (part II): Fujita-Miyazawa Mechanism

( J. Fujita, H. Miyazawa; Prog.Theor. Phys. 17 (1957) 360 )

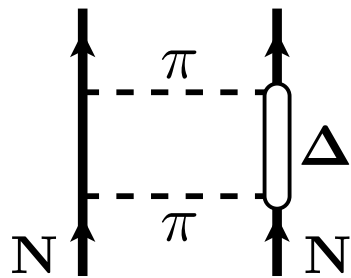

**large  
spin-isospin polarizability**

$$\beta_{\Delta} = \frac{g_A^2}{f_{\pi}^2 (M_{\Delta} - M_N)} \sim 5 \text{ fm}^3$$



**strong  
3-body  
interaction**

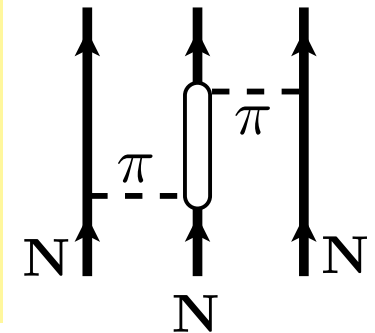

- **Pionic Van der Waals** - type intermediate range central potential

$$V_c(\mathbf{r}) = -\frac{9 g_A^2}{32 \pi^2 f_{\pi}^2} \beta_{\Delta} \frac{e^{-2m_{\pi} r}}{r^6} P(m_{\pi} \mathbf{r})$$

N. Kaiser, S. Fritsch, W.W.  
Nucl. Phys. A750 (2005) 259

- **Large** contribution to **spin-orbit interaction**

$$F_{LS}^{(\Delta)} \simeq (50 - 70) \text{ MeV fm}^5$$

- How can there be a coexistence between **short-distance** and Fujita-Miyazawa **two-pion exchange** mechanisms ?



# Spin-Orbit Coupling in $\Lambda$ -Hypernuclei

- **Central Potential**
- **Spin-Orbit Potential**

$$U_0^{(\Lambda)} \simeq \frac{1}{2} U_0^{(N)}$$

$$U_{LS}^{(\Lambda)} \leq \frac{1}{20} U_{LS}^{(N)}$$

$^{13}\text{C}$  ( $K^-, \pi^-, \gamma$ ) BNL E929 (NaI)

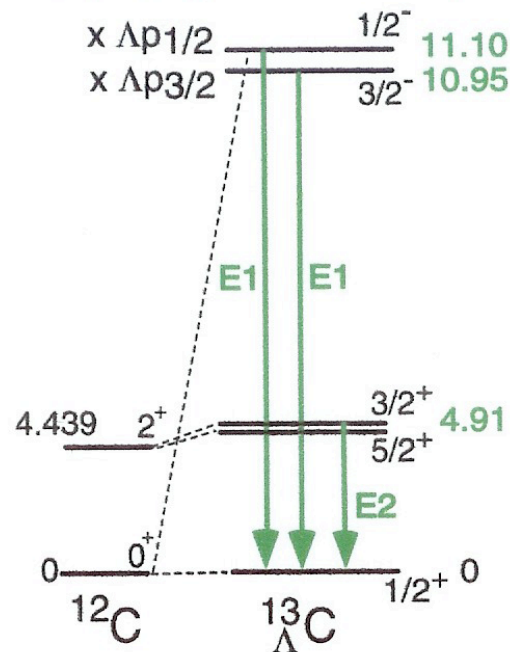

PRL 86 (2001) 4255

$$E_{\Lambda}(p_{1/2}) - E_{\Lambda}(p_{3/2}) = (152 \pm 54 \pm 36) \text{ keV}$$

**unusually small:**

more than 20 times smaller than the  $p_{1/2} - p_{3/2}$  spin-orbit splitting of about 5 MeV for nucleons in nuclei

- ... cannot be understood in terms of short-distance dynamics

scalar-vector mean fields

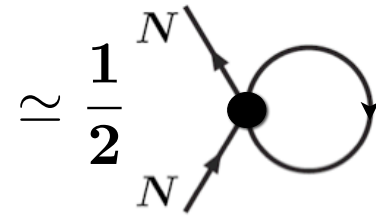
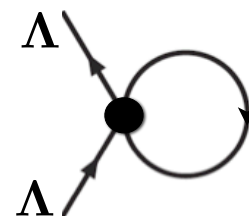

**2.**

**Chiral Dynamics  
and  
Spin-Orbit Interactions**

# CHIRAL DYNAMICS and the NUCLEAR MANY-BODY PROBLEM

- Relevant “small” scales:

$$p_F \sim 2 m_\pi \sim M_\Delta - M_N \ll 4\pi f_\pi \sim 1 \text{ GeV}$$

- **PIONS** (and **DELTA** isobars) as **explicit** degrees of freedom

- **IN-MEDIUM CHIRAL PERTURBATION THEORY**

→ pion exchange in presence of filled Fermi sea

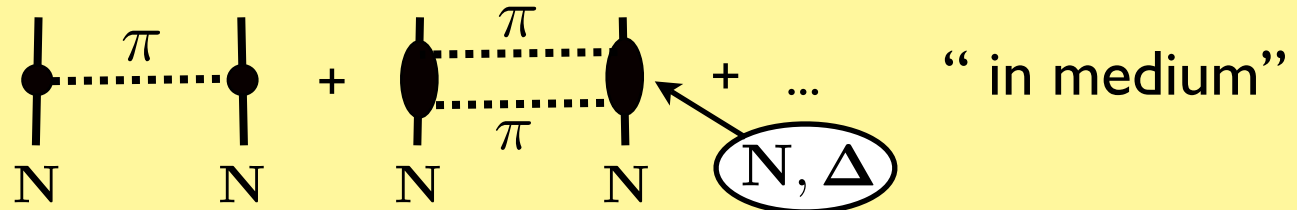

2nd order TENSOR force + nucleon’s SPIN-ISOSPIN polarizability

→ short-distance dynamics: contact interactions

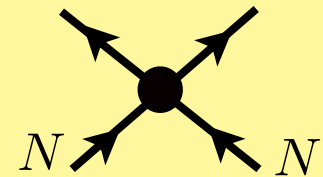

# CHIRAL DYNAMICS and the NUCLEAR MANY-BODY PROBLEM (contd.)

- Compute **energy density**  $\mathcal{E}(p_F)$  using  
**in-medium chiral perturbation theory**  
(3-loop order)

N. Kaiser, S. Fritsch, W.W. (2002-2005)



- result: **realistic nuclear matter** equation of state
- **spin-dependent nucleon self-energy**  
in (slightly) inhomogeneous nuclear matter
- 2nd order **tensor force** produces **spin-orbit term**

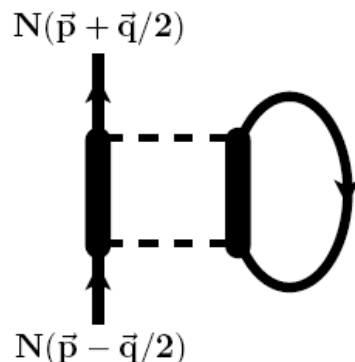

$$\Sigma_{LS}(\vec{p}, \vec{q}) = U_{LS}(p_F) \mathbf{i} \vec{s} \cdot (\vec{q} \times \vec{p})$$



# Iterated ONE-PION EXCHANGE

- Kaiser's "WRONG SIGN" Spin-Orbit Interaction -

N. Kaiser  
PRC70 (2004) 034307

N. Kaiser, W.W.  
NPA804 (2008) 60



$$F_{\text{LS}}^{(\pi\pi)}(\rho) = \frac{m_\pi M_N}{64\pi} \left( \frac{g_A}{f_\pi} \right)^4 \left[ \frac{1}{m_\pi^2 + 4p_F^2} - \frac{3}{8p_F^2} \ln \left( 1 + \frac{4p_F^2}{m_\pi^2} \right) \right] - \text{exch.}$$

- **Hartree term:**

$$- 87 \text{ MeV fm}^5$$

at  $\rho = \rho_0$

**cancels**  
short-distance  
spin-orbit  
contribution

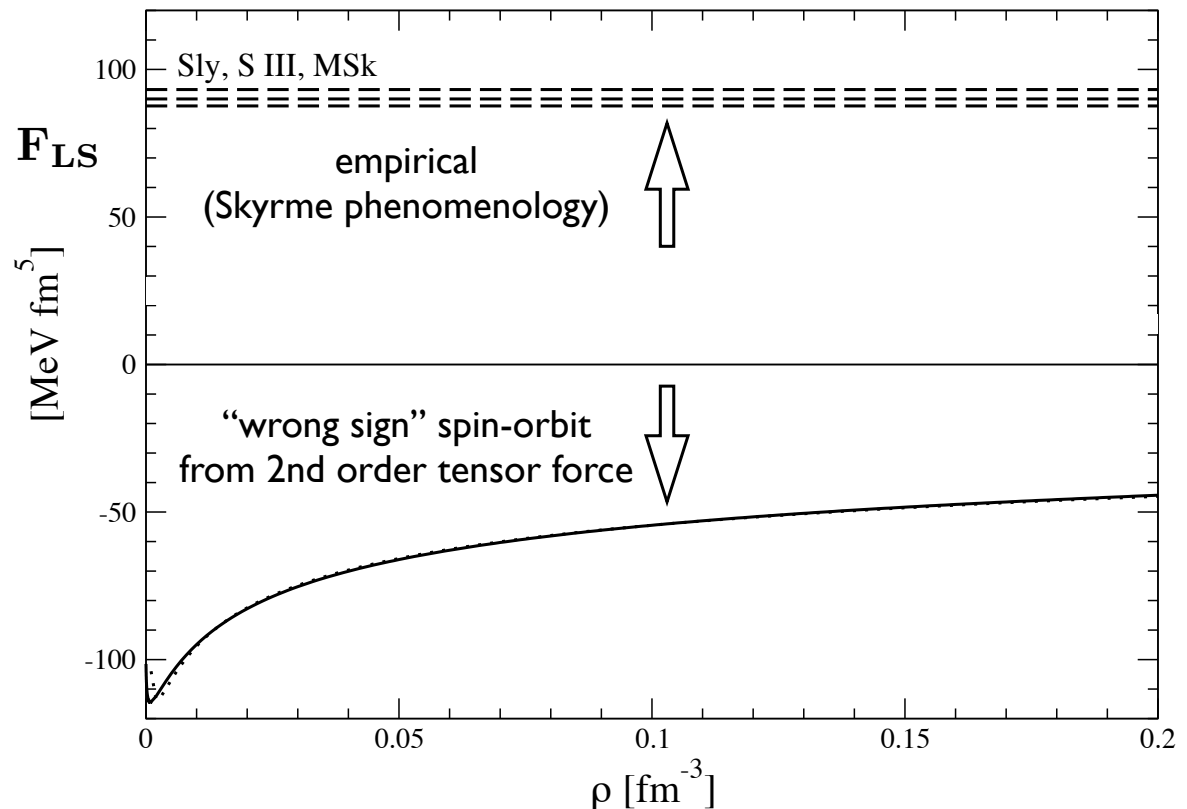

# TWO-PION EXCHANGE

## Spin-Orbit Interaction: $\Delta(1230)$ and 3-Body Terms

S. Fritsch, N. Kaiser, W.W.  
NPA750 (2005) 259

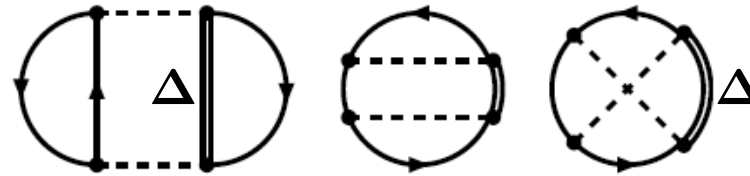

$$F_{LS}^{(\Delta)}(\rho) = \frac{g_A^4}{8\pi^2 f_\pi^4 (M_\Delta - M_N)} \left[ \frac{m_\pi^2 p_F + p_F^3}{m_\pi^2 + 4p_F^2} - \frac{m_\pi^2}{4p_F} \ln \left( 1 + \frac{4p_F^2}{m_\pi^2} \right) \right] - \text{exch.}$$

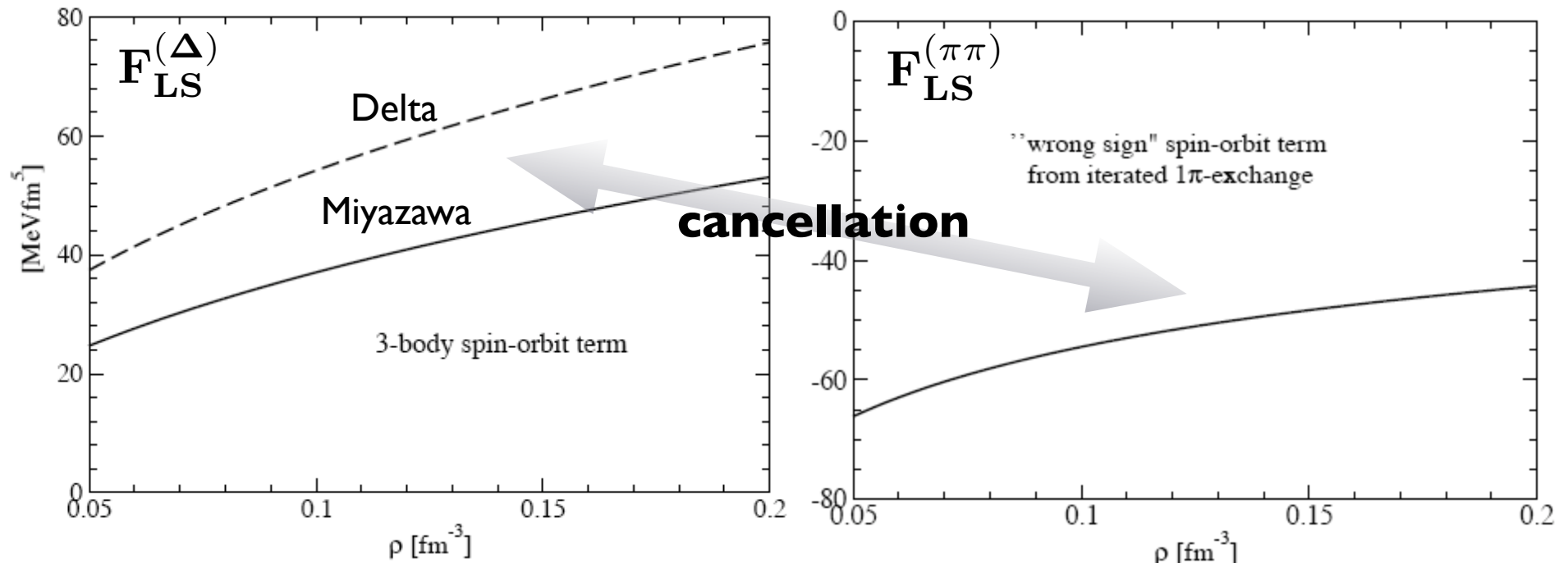

# Intermediate Summary: Balance of Spin-Orbit Terms

- **Three** major contributions to **nuclear** spin-orbit interactions:

- ▶ **Short-distance** component (strong **scalar** and **vector** fields) ← **survives**
- ▶ “**Wrong-sign**” spin-orbit term generated by 2nd order **pion exchange tensor force**
- ▶ **Three-body** term induced by **two-pion exchange** with intermediate **Delta**(1230) (à la Fujita-Miyazawa) ↔ **cancellation**

- Learn more about underlying mechanisms by comparison with **hypernuclear** spin-orbit forces (different balance of terms)



**3.**  
**Chiral SU(3) Dynamics**  
and  
**Spin-Orbit Interaction**  
in  
 **$\Lambda$  - Hypernuclei**



# $\Lambda$ HYPERON SELF-ENERGY

- **short-distance** (contact) terms  
( e.g. **scalar-vector mean fields** )

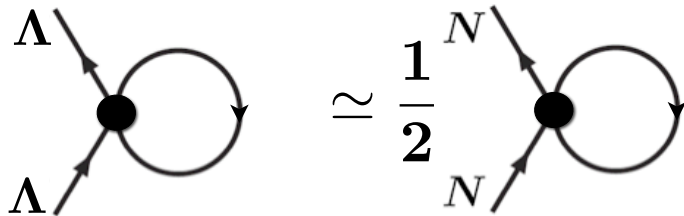

- **small:**  
( K exchange **Fock term** )

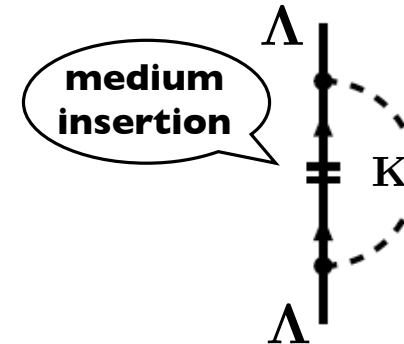

- **large:** **two-pion exchange** mechanisms

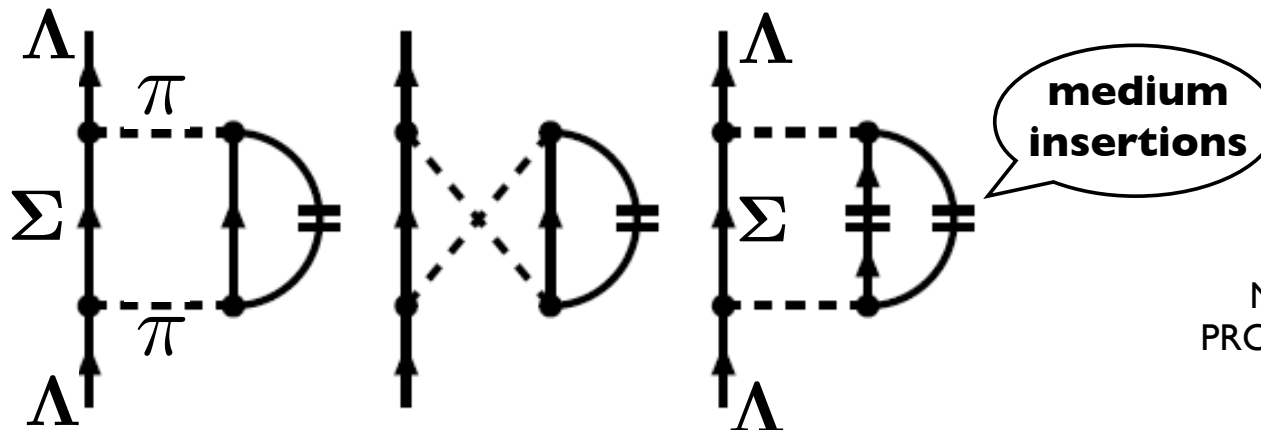

N. Kaiser, W.W.  
PRC71 (2005) 015203

- 2nd order **tensor force** produces **spin-orbit term**

$$\Sigma_{LS}^{(\Lambda)}(\vec{p}, \vec{q}) = U_{LS}^{(\Lambda)}(p_F) i \vec{s} \cdot (\vec{q} \times \vec{p})$$



# Spin-Orbit Coupling in $\Lambda$ -Hypernuclei

- **cancellation** between **short-distance** (contact) and **two-pion exchange** terms

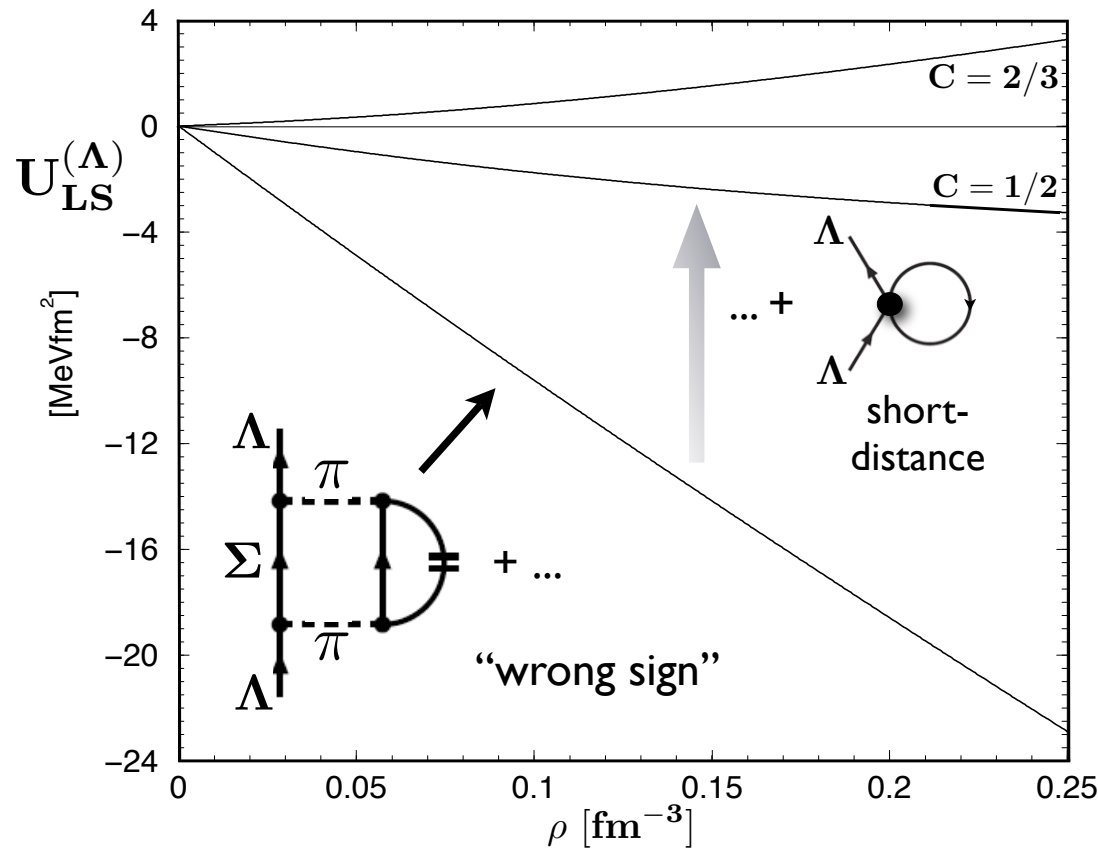

$$U_{LS}^{(\Lambda)} = C \left( \frac{M_N}{M_\Lambda} \right)^2 U_{LS}^{(N)}$$

for short-distance terms

N. Kaiser, W.W.  
PRC71 (2005) 015203

- **NO three-body** terms á la Miyazawa: no hyperon Fermi sea



# Finite Systems

- translate **in-medium chiral dynamics** → **density functional**  
add surface terms (calculable)
- very satisfactory results for systematics of **nuclei** and **hypernuclei**
- example:  $^{16}\text{O}_\Lambda$

$$\varepsilon_\Lambda(\mathbf{p}_{1/2}) - \varepsilon_\Lambda(\mathbf{p}_{3/2})$$

[MeV]

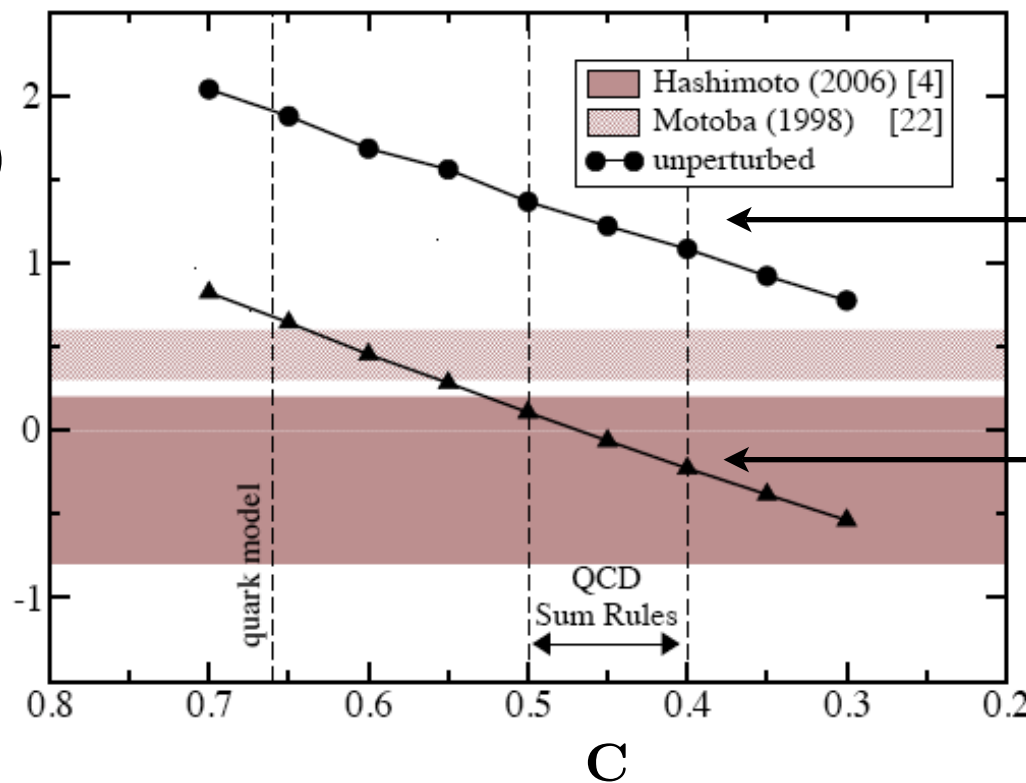

P. Finelli, N. Kaiser,  
D.Vretenar, W.W.  
PLB658 (2007) 90



# SUMMARY

- towards resolution of

## Hypernuclear vs. Nuclear Spin-Orbit puzzles

based on in-medium Chiral Effective Field Theory

	Nucleons		Hyperons	
short-distance Hartree		+		+
in-medium ChPT (2nd order tensor)		-		-
in-medium ChPT (3-body)		+	no contributions	×
	large and positive		small	

QCD sum rules  
NN contact terms  
scalar-vector MF

“wrong sign”  
spin-orbit  
(Kaiser)

Fujita-  
Miyazawa  
mechanism

- Comparisons between **nuclei** and **hypernuclei** useful in studying the role of 3-body interaction mechanisms

